



www.sesamemotor.com

PRECISION GEAR MOTOR

V-CASING & FOOT-MOUNT TYPES

齒輪馬達·立式/臥式系列





品名定義

PRODUCT NAME CODING SYSTEM

● 中型齒輪減速變速馬達 PRECISION GEAR MOTOR

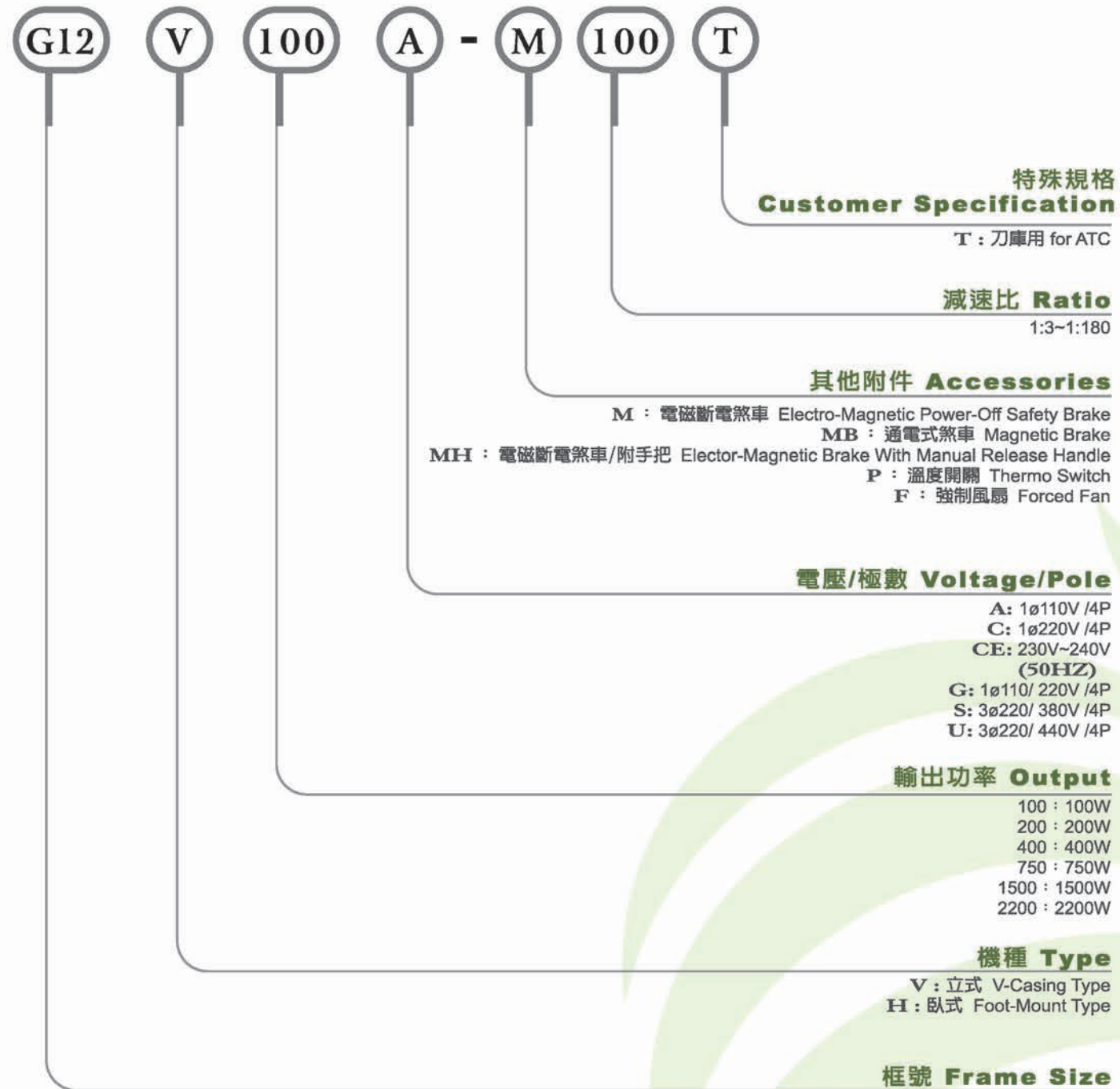

(G11, G12, G13) 鋁合金齒箱 Aluminum Alloy Casting Housing
 (GE11, GE12, G14, G15) 鑄鐵齒箱 Cast Iron Housing

電流表

AMPERE TABLE

馬力 (KW)	全負荷電流 Full Load Current (amp)								滿載迴轉數 Full Load Revolutions (rpm)	
	三相 (3 Phase)				單相 (1 Phase)					
	220V		380V		100V	110V	200V	220V	50HZ	60HZ
100W	0.66	0.58	0.35	0.32	2.42	1.89	1.11	1.06	1400	1700
200W	1.28	1.29	0.72	0.66	4.65	3.50	2.30	1.93	1400	1700
400W	2.28	1.87	1.32	1.09	8.28	7.48	4.26	4.54	1400	1700
750W	4.00	3.40	2.30	2.00	18.40	19.10	9.72	7.65	1400	1700
1500W	7.43	6.66	4.09	3.75	-	-	-	-	1400	1700
2200W	9.38	8.87	5.24	5.15	-	-	-	-	1400	1700



精密齒輪馬達 操作說明書

Precision Gear Motor Operation Manual

1. 注意事項

1.1 安裝前準備

- 使用前請熟讀“操作說明書”，若因人為原因、非產品本身原因或天災發生等因素而導致不良或損壞，在操作時違反本說明書所示內容而造成的損害，或未依照原本設計之使用方式及非經由本公司進行的改裝及維修所造成的故障，本公司將不承擔任何賠償責任，特此聲明，敬請見諒。
- 本公司的產品保固期間為購買產品後一年內。保固期限內，若產品因非人為因素而發生故障，客戶將產品寄回，本公司免費更換受損零件。
- 安裝前請先確定使用正確之電壓規格。
- 請勿施壓於出口線上。
- 請指定技術人員進行安裝。
- 請按照接線圖確實地進行接線，否則有可能引起火災或觸電。
- 請勿對馬達進行拆解或改造，否則有可能引起觸電或受傷。

1.2 安裝環境的限制

- 馬達必須依據下列條件安裝，不符合下列之安裝條件及使用環境將會損害到本馬達，不在保固範圍內。
- 本產品之設計或製造，為使用裝配於其他之機械設備上。
 - 避免將馬達使用於可燃氣體或腐蝕氣體之環境。
 - 限使用於室內。周溫範圍-10°C ~ +50°C（電容組合馬達-10°C ~ +40°C）。
 - 溼度: 不可超過85%，以避免水氣凝結。
 - 高度: 不可超過海平面1000公尺。
 - 避免陽光直射，灰塵堆積。
 - 避免水或油的噴濺。
 - 避免連續性震動或撞擊。
 - 使用於良好通風之場所。

1.3 操作準備

- 馬達啟動前請檢查電源。
- 高溫會損害線圈或培林之壽命。
- 使用前請先確認電容器規格。
- 請勿搭配變頻器使用。
- 馬達接線錯誤會導致馬達燒毀。
- 馬達超負荷使用有燒毀之虞。

2. 負荷之取用及安裝方法

出力軸外徑為研磨加工，並以鍵槽作為傳動媒介，故傳動元件內孔請預銑鍵槽以便安裝。

〈臥式馬達〉

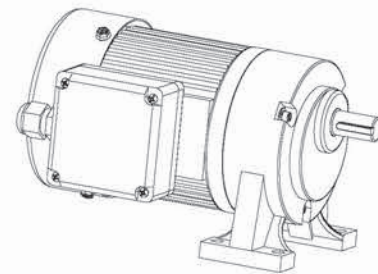

〈立式馬達〉

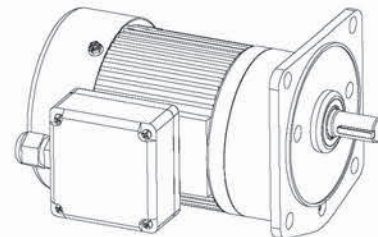

⚠ 請注意

- 安裝過程中，請勿以任何工具敲擊，以免損壞馬達。
- 將本公司產品與其他產品搭配使用時，請確認是否符合客戶所需之規格、法規或限制等。
- 此外，請客戶自行確認目前所使用的系統、機械或是裝置是否適用於本公司產品。
- 如未確認是否符合或適用時，本公司無須對本公司產品的適用性負責。

3. 配線圖

- 馬達運轉方向為從輸出軸上目測到的方向。正轉方向為順時鐘，逆轉方向為逆時鐘。

3.1 三相馬達

- 三相馬達依據出線數不同，接線方式請參考下圖。需逆轉時請將入電三線中任兩線交換即可。
- 三相馬達接線完成後請確實檢查，防止欠相及相位電壓不平衡。

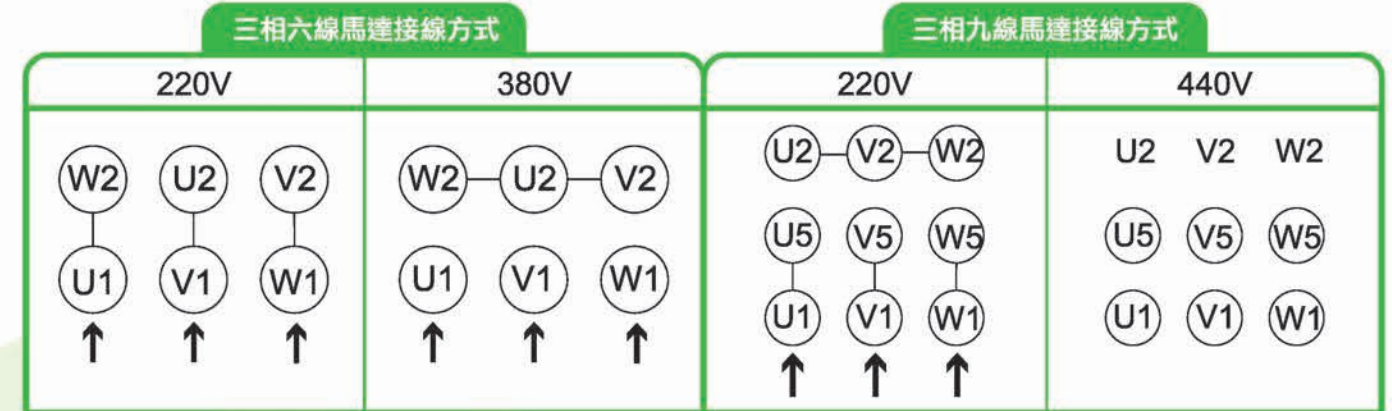

3.2 三相剎車馬達

三相剎車馬達接線方式

YELLOW IN-AC 200(220)
BLACK OUT-DC 90V

CONNECTION

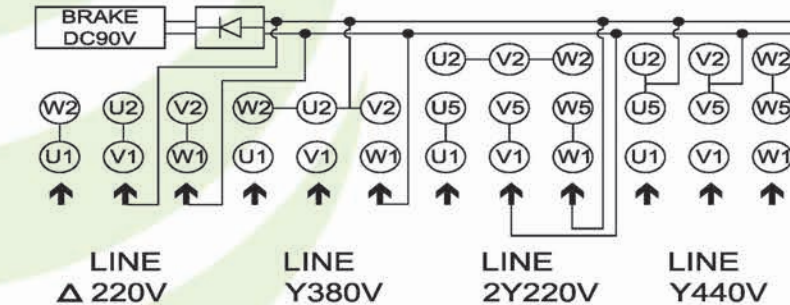

3.3 單相馬達

單相三線馬達接線方式

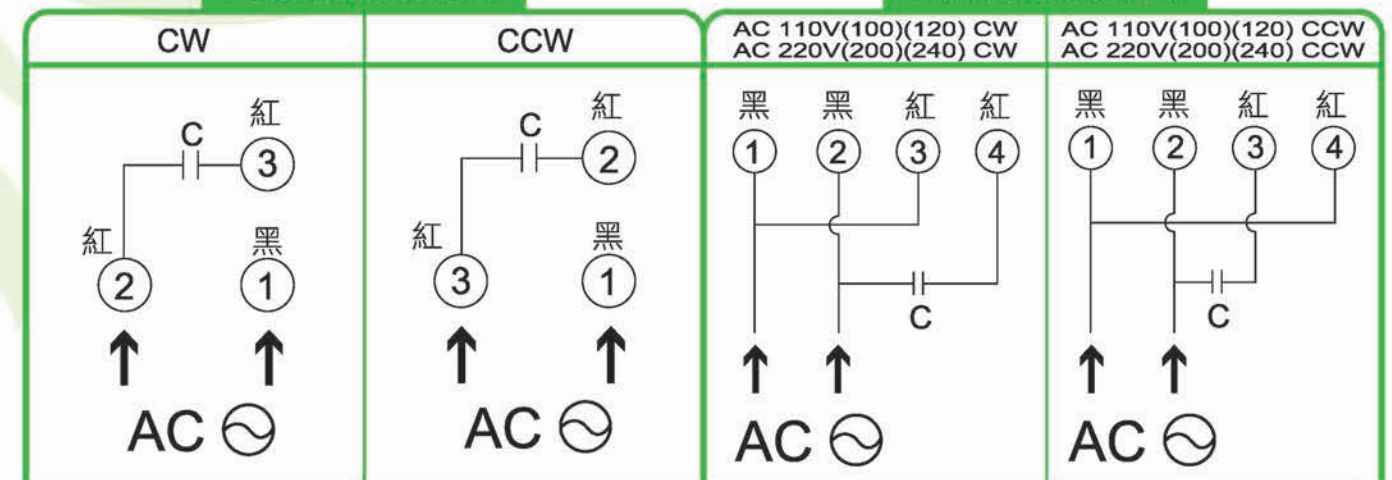



3. 配線圖(續)

3.3 單相馬達

單相六線馬達接線方式

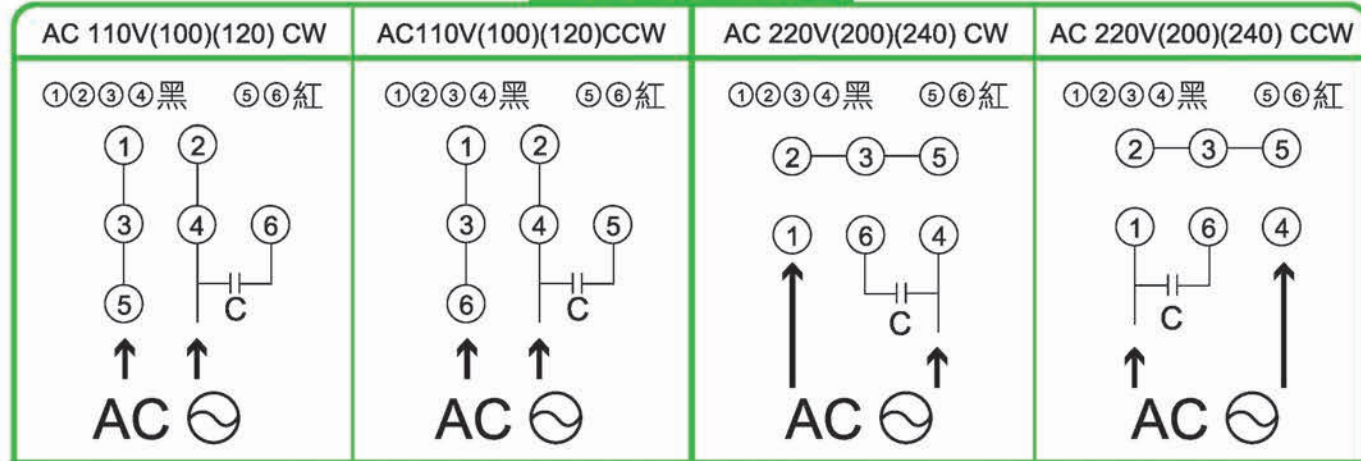

3.3 單相馬達

單相剎車馬達接線方式

● 若選配之剎車電路板，無內部繼電器，配線方式請參考下列配線圖。

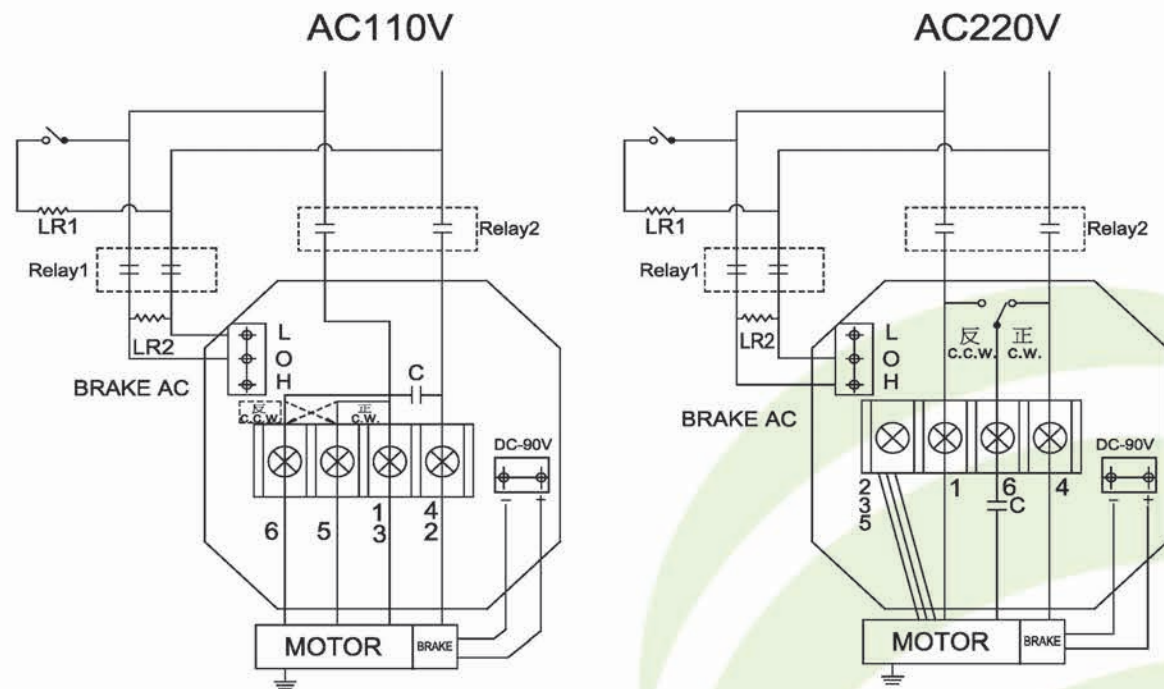

● 若選配之剎車電路板，無內部繼電器，配線方式請參考下列配線圖。

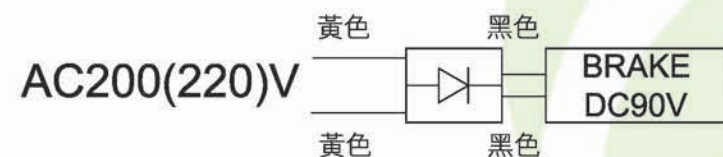

4. 電容器安裝須知 (僅附於單相馬達)

- 請再確認附屬的電容器容量是否符合馬達銘板上所記載的電容量再進行安裝。
- 安裝電容器時請用所附之電容器束環以M5 的螺絲固定(本電容器不附安裝螺絲)。

⚠ 請注意

▶ 電容器之安裝位置要離馬達外殼 10cm 以上，以防電容器會因受熱而縮短使用壽命。

5. 故障排除步驟

馬達動作異常時，請依步驟進行檢查。

- 馬達不轉或轉速無法提升
 - 馬達電壓是否符合規格?
 - 電源連接是否準確?
 - 負載是否過大?
 - 使用端子台或者壓接端子作連結時是否有接觸不良的狀況?
 - 電容器是否規格正確或安裝妥當?
 - 馬達異常發熱
 - 馬達電壓是否符合規格?
 - 環境溫度是否過高(需 < 40°C)?
 - 電容器是否正確?
 - 馬達發出異音
 - 確認是否有異物卡住?
 - 確認是否欠相?
 - 剎車器功能是否正常?
 - 風扇葉是否鬆脫?
- 若經以上檢查仍無法查出故障原因，請勿進行拆解，請儘快與世協電機連絡，以取得技術協助。



精密齒輪馬達 操作說明書

Precision Gear Motor Operation Manual

1. Attention

1.1 Install preparation

- Please read this operation manual before using this motors. Any problems caused by inappropriate operation contrary with the manual, or damage caused by natural disasters, or restructure without our permission, Sesame will not take any responsibility nor will the motor / speed reducer be cover by warranty.
- Warranty is within one year after purchase. Within warranty period, if motor / speed reducer damage is not caused by operation error or by natural disaster, then please send back the product, we should replace the damaged spare part at free of charge.
- Before Installation, ensure correct voltage can be applied to motor.
- Do not bend the lead wires.
- Installation should be proceeded by trained technicians only.
- Please wire motor correctly according to the manual to prevent fire or electrical shock.
- Do not attempt to disassemble or modify the motor to prevent electrical shock or injury.

1.2 Installation Conditions

- The conditions below must be fulfilled to avoid any motor damage, which is not covered under warranty.
- The motor was designed to be installed on the other facilities/applications.
 - Do not expose the motor to flammable or corrosive gas.
 - Indoor application only. Room temperature should be maintained between -10-50°C (-10-40°C for motor with capacitor)
 - The air humidity should not exceed 85%.
 - The altitude of where the motor was installed should not exceed 1000 meter above the sea level.
 - Do not expose the motor to the sunshine directly. Dust and spray of oil/water is also forbidden.
 - Avoid any continuous vibration or impact on the motor.
 - Ensure the motor was installed in a well ventilated location.

1.3 Preparation of start up

- Please check the power supply before starting the motor.
- High temperature might cause the coil and bearing failed earlier.
- Do not connect the motor with inverter.
- Motor might burn out if wrong wiring or overloaded.

2. Loading Installation Method

The output shaft surface was precisely grinded, it needed to milling a hole for input the keyway since the keyway is the transmission media, between motor and application.

<Foot-Mount type>

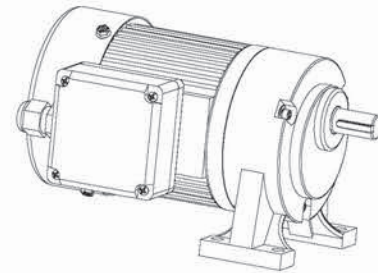

<V-Casing type>

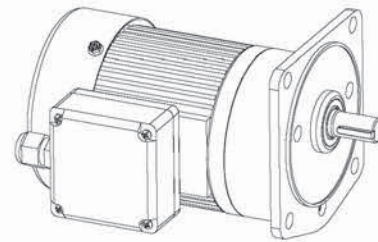

⚠ Attention

- Do not knock the motor by any tool during installation.
- The motor with gear shaft can only been mounted with adequate gear box. Please confirm the specification of gearbox before installation.
- Apply our product with other, please ensure it match other' s requirement, specification, or limitation.
- Customer need to recheck our product is suitable for their current system or machinery usage.
- If customer is neglecting for rechecking, then Sesame is not responsible for any cause there might occur.

3. Wiring Diagrams

- Visual direction for Motor running direction is from motor's the output shaft. Forward direction is clockwise, counterclockwise direction for reversal.

3.1 Three phases motor

- Please wire the power supply according to the incoming voltage as shown below. Whenever the rotating direction needs to be reversed, switch any two wires of the incoming power cable.
- Please check if the wiring is correct after installation, ensure there is no missing phase, or phase voltage unbalance.

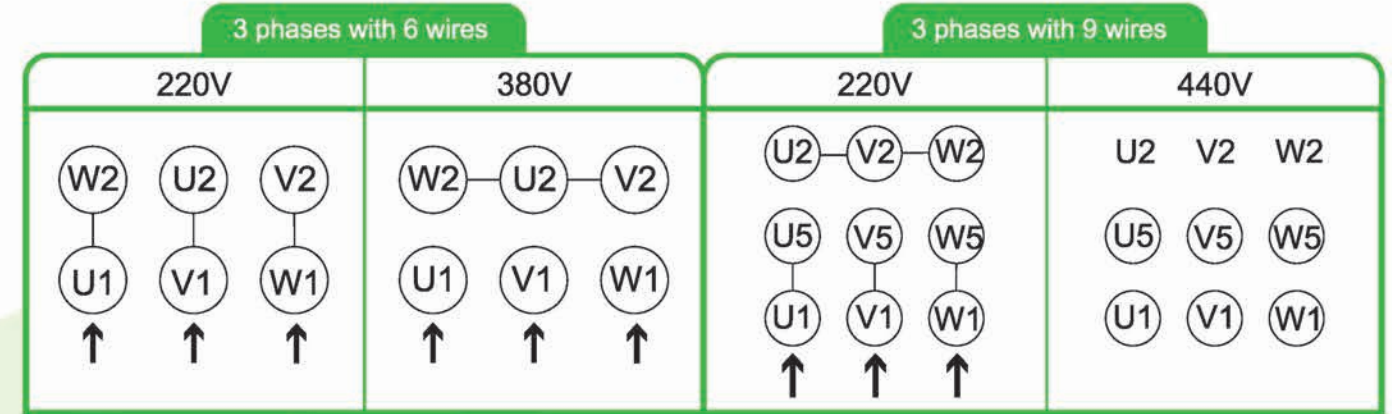

3.2 Three phases motor with brake

3 phase brake motor wiring instruction

YELLOW IN-AC 200(220)
 BLACK OUT-DC 90V

CONNECTION

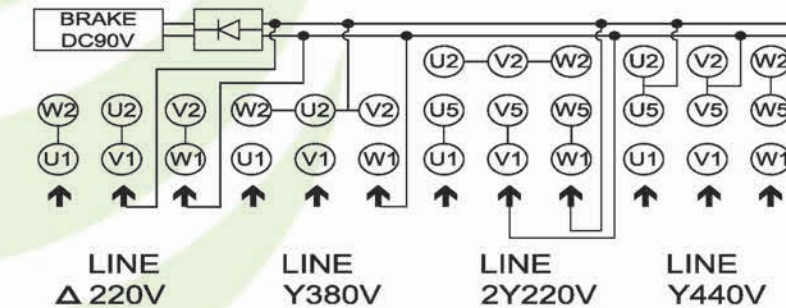

3.3 Single phase motor

Wiring instruction of single phases with 3 wires

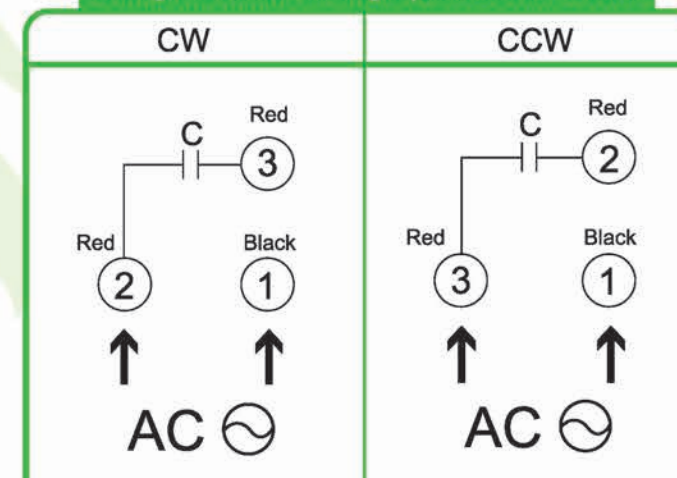

Wiring instruction of single phases with 4 wires

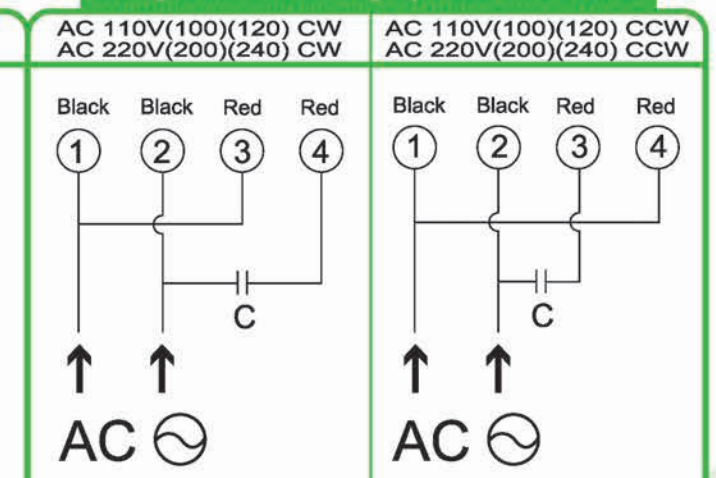

3. Wiring Diagrams(cont.)

3.3 Single phase motor

Wiring instruction of 3 phases with 6 wires

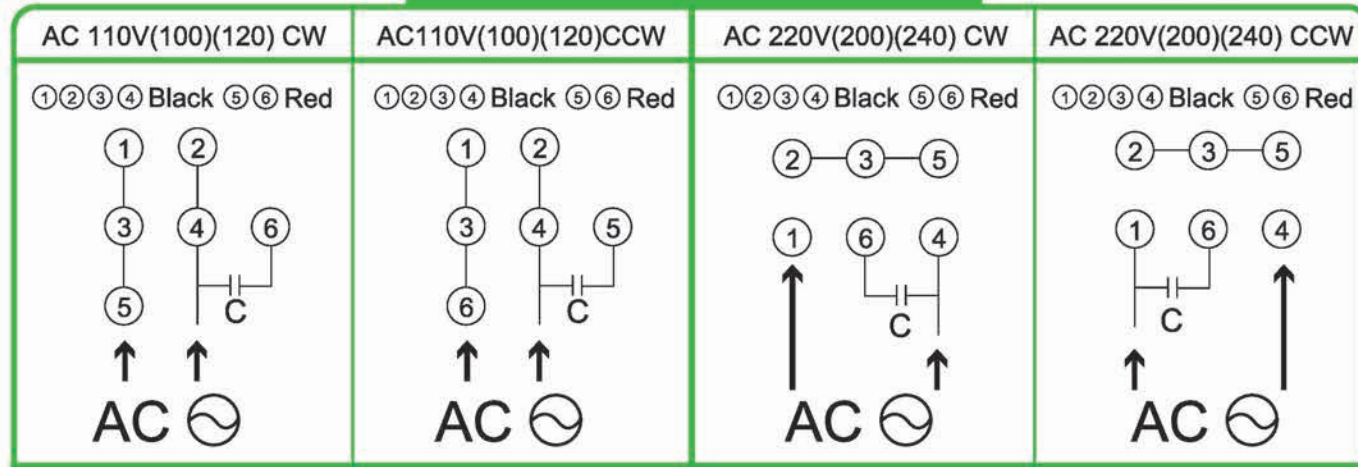

3.4 Single phase motor with brake

Single Phase Brake Motor Wiring Instruction

● Brake control panel without relay, wiring diagram

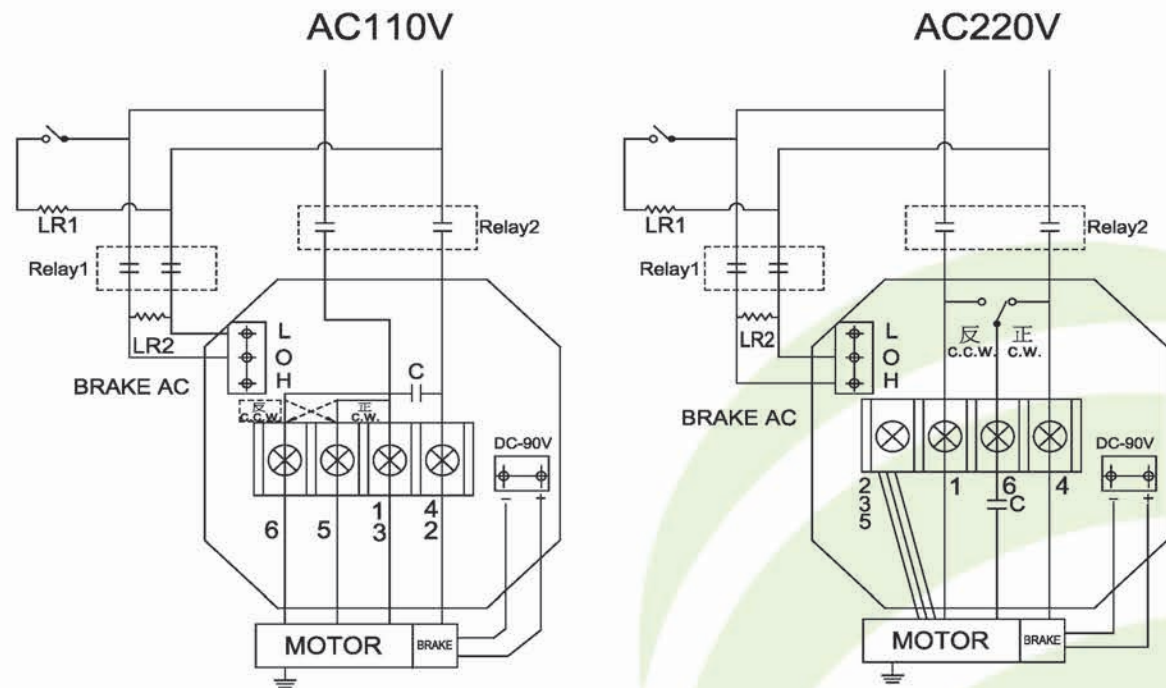

● Brake control panel with relay, wiring diagram

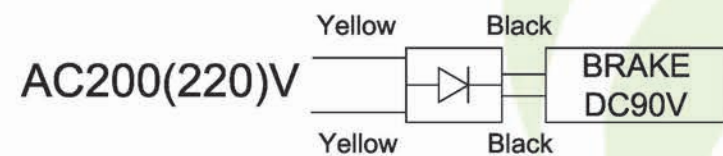

4. Installation of Capacitor (Single Phase Motor Only)

- Ensure the capacity matches the specification of the motor before installation.
- Install the capacity with M5 screws (not included).

⚠ Attention

▶ The distance between the capacity and the motor should be longer than 10 cm.

5. Trouble Shooting

Please check the motor according to procedures below if abnormal situation.

- The motor does not work or the speed cannot be raised.
 - Check if the power supply fits the motor specification?
 - Confirm if the power supply is correctly connected?
 - Confirm if the motor is overloaded?
 - Confirm if the wires are poor connected when using crimping terminal or terminal block?
 - Confirm if the capacitor is well installed?
- The motor is over heated
 - Check if the power supply fits the motor specification?
 - Check if the room temperature is under the requirement (< 40°C)?
 - Confirm if the capacitor specification is correct?
- Noise
 - Check if the motor was blocked?
 - Check if a phase failure occurs?
 - Check if brake well functioning?
 - Check if the fan loosens?
- If the problem could not be solved via the procedures above, please do not take apart the products, contact Sesame for technical support.



立式齒輪馬達 外型尺寸圖表

SPECIFICATIONS AND DIMENSIONS, V-CASING TYPE

立式標準型馬達的接線盒位置在270°
 Terminal box position: At 270° for V-casing type.

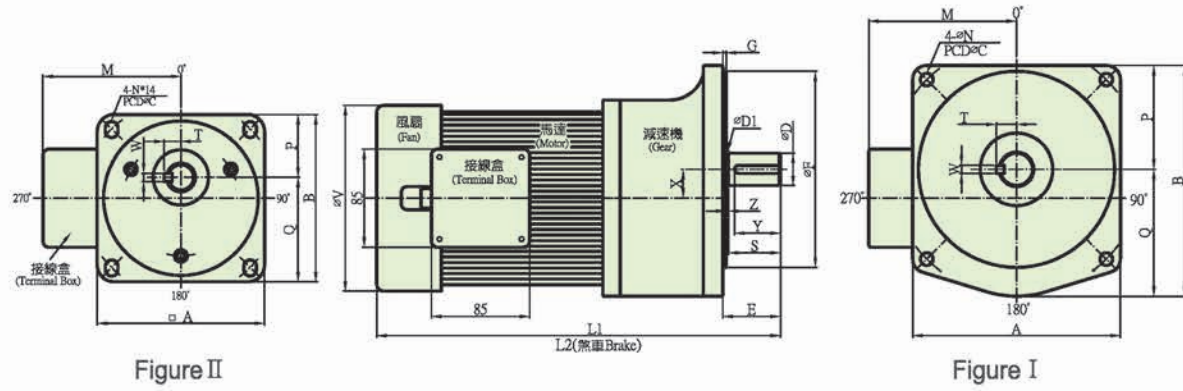

Figure II 立式尺寸表 DIMENSION (mm)

馬達容量 MOTOR'S CAPACITY	圖示 FIGURE NO.	型號 TYPE NO.	減速比 GEAR RATIO	出力軸 OUTPUT SHAFT																				
				A	B	C	E	F	G	L1	L2	M	N	P	Q	V	X	D	D1	S	T	W	Y	Z
100W 1/8HP x4P	II	11	1/3~1/90	122	122	140	42	-	-	252	297	112	9x12	43	79	133	18	18	20	32	11.5	5	28	4
	II	E11	1/3~1/90	145	145	170	42.5	-	-	251	296	112	11x14	54.5	90.5	133	18	22	25	35	14.5	7	28	2.5
	I	12	1/75~1/165	155	167	185	50.5	140	3	273	318	112	11	77.5	89.5	133	18	22	25	40	14.5	7	35	7.5
	II	E12	1/75~1/165	145	145	170	50.5	-	-	273	318	112	11x14	54.5	90.5	133	18	22	25	40	14.5	7	35	7.5
200W 1/4HP x4P	II	11	1/3~1/40	122	122	140	42	-	-	277	322	112	9x12	43	79	133	18	18	20	32	11.5	5	28	4
	II	E11	1/50~1/90	145	145	170	42.5	-	-	276	321	112	11x14	54.5	90.5	133	18	22	25	35	14.5	7	28	2.5
	I	12	1/20~1/90	155	167	185	50.5	140	3	298	343	112	11	77.5	89.5	133	18	22	25	40	14.5	7	35	7.5
	II	E12	1/100~1/165	145	145	170	50.5	-	-	298	343	112	11x14	54.5	90.5	133	18	22	25	40	14.5	7	35	7.5
400W 1/2HP x4P	I	13	1/100~1/180	180	200	220	50	170	3	322	367	112	11	90	110	133	25	28	30	45	17.5	7	40	2
	I	12	1/3~1/40	155	167	185	50.5	140	3	324	360	119.5	11	77.5	89.5	147	18	22	25	40	14.5	7	35	7.5
	II	E12	1/50~1/90	145	145	170	50.5	-	-	325.5	360	119.5	11x14	54.5	90.5	147	18	22	25	40	14.5	7	35	7.5
	I	13	1/50~1/90	180	200	220	50	170	3	350	384.5	119.5	11	90	110	147	25	28	30	45	17.5	7	40	2
750W 1HP x4P	I	13	1/100~1/180	180	200	220	50	170	3	350	393.5	128	11	90	110	161	25	28	30	45	17.5	7	40	2
	I	14	1/30~1/90	209	230	255	66	185	4	376	410.5	119.5	13	104	126	147	26	32	35	55	20	10	50	7
	I	13	1/50~1/90	180	200	220	50	170	3	350	393.5	128	11	90	110	161	25	28	30	45	17.5	7	40	2
	I	14	1/100~1/180	209	230	255	66	185	4	376	419.5	128	13	104	126	161	26	32	35	55	20	10	50	7
1500W 2HP x4P	I	15	1/100~1/190	251	267.5	310	71	230	5	408	451.5	128	15	124.5	143	161	28	40	40	71	24	10	60	-
	I	14	1/3~1/60	209	230	255	66	185	4	418	454.5	138.5	13	104	126	192	26	32	35	55	20	10	50	7
2200W 3HP x4P	I	15	1/50~1/90	251	267.5	310	71	230	5	450	486.5	138.5	15	124.5	143	192	28	40	40	71	24	10	60	-
	I	14	1/3~1/40	209	230	255	66	185	4	448	484.5	138.5	13	104	126	192	26	32	35	55	20	10	50	7

※ 以上數字若有變更，恕不另行通知。 Factory retains modification. 減速比 (■) 表輕負載機型。 For light loading type.

- 在正常使用狀態下，產品保固期限一年。
- 本公司有權針對以上數據規格進行設計變更不另行通知。
- Under normal usage, products come with a one-year limited warranty.
- Specifications subject to change without notice.

臥式齒輪馬達 外型尺寸圖表

SPECIFICATIONS AND DIMENSIONS, FOOT-MOUNT TYPE

臥式標準型馬達的接線盒位置在270°
 Terminal box position: At 270° for foot - mount type.

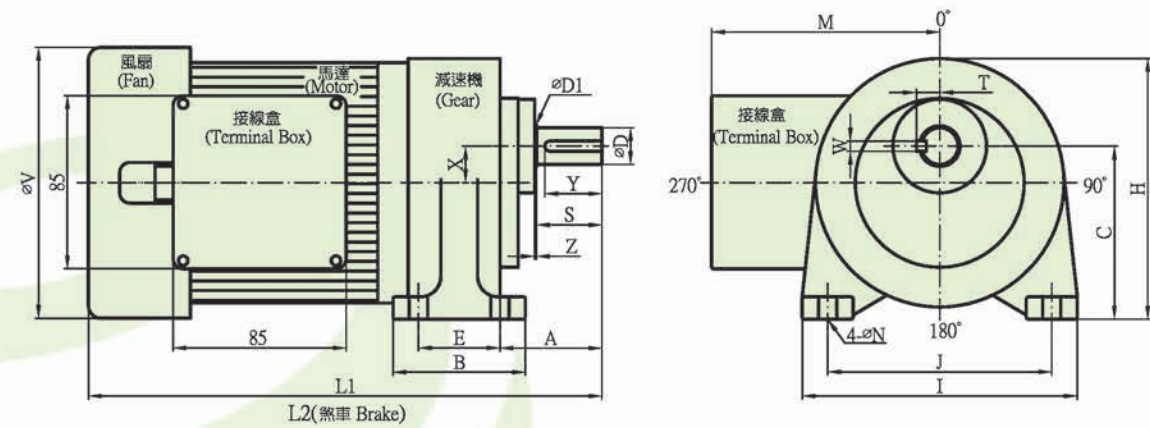

Figure I 臥式尺寸表 DIMENSION (mm)

馬達容量 MOTOR'S CAPACITY	型號 TYPE NO.	減速比 GEAR RATIO	出力軸 OUTPUT SHAFT																			
			A	B	C	E	H	I	J	L1	L2	M	N	V	X	D	D1	S	T	W	Y	Z
100W 1/8HP x4P	11	1/3~1/90	50	65	85	40	128	135	110	252	297	112	9	133	18	18	20	32	11.5	5	28	1
	11	1/3~1/90	50	65	85	40	128	135	110	252	297	112	9	133	18	18	20	32	11.5	5	28	1
	12	1/75~1/165	60	90	94	65	147.5	158	130	270	315	112	11	133	18	22	25	40	14.5	7	35	8.5
200W 1/4HP x4P	11	1/3~1/40	50	65	85	40	128	135	110	277	322	112	9	133	18	18	20	32	11.5	5	28	1
	11	1/50~1/90	50	65	85	40	128	135	110	277	322	112	9	133	18	18	20	32	11.5	5	28	1
	12	1/20~1/90	60	90	94	65	147.5	158	130	295	340	112	11	133	18	22	25	40	14.5	7	35	8.5
	12	1/100~1/165	60	90	94	65	147.5	158	130	295	340	112	11	133	18	22	25	40	14.5	7	35	8.5
400W 1/2HP x4P	12	1/3~1/40	60	90	94	65	147.5	158	130	321	355.5	119.5	11	147	18	22	25	40	14.5	7	35	8.5
	12	1/50~1/90	60	90	94	65	147.5	158	130	321	355.5	119.5	11	147	18	22	25	40	14.5	7	35	8.5
	13	1/50~1/90	68	120	115	90	175	180	140	350	384.5	119.5	11	147	25	28	30	45	17.5	7	40	2
	13	1/100~1/180	68	120	115	90	175	180	140	350	384.5	119.5	11	147	25	28	30	45	17.5	7	40	2
750W 1HP x4P	13	1/3~1/30	68	120	115	90	175	180	140	350	393.5	128	11	161	25	28	30	45	17.5	7	40	2
	13	1/50~1/90	68	120	115	90	175	180	140	350	393.5	128	11	161	25	28	30	45	17.5	7	40	2
	14	1/30~1/90	74	165	130	130	204	210	170	376	419.5	128	13	161	26	32	35	55	20	10	50	7
	14	1/100~1/180	74	165	130	130	204	210	170	376	419.5	128	13	161	26	32	35	55	20	10	50	7
1500W 2HP x4P	15	1/100~1/190	95	195	150	150	237	255	210	412	455.5	128	15	161	28	40	-	69	24	10	60	-
	14	1/3~1/60	74	165	130	130	204	210	170	418	454.5	138.5	13	192	26	32	35	55	20	10	50	7
	15	1/50~1/90	95	195	150	150	237	255	210	454	490.5	138.5	15	192	28	40	-	69	24	10	60	-
2200W 3HP x4P	14	1/3~1/40	74	165	130	130	204	210	170	448	484.5	138.5	13	192	26	32	35	55	20	10	50	7
	15	1/3~1/40	95	195	150	150	237	255	210	484	520.5	138.5	15	192	28	40	-	69	24	10	60	-
	15	1/50~1/90	95	195	150	150	237	255	210	484	520.5	138.5	15	192	28	40	-	69	24	10	60	-

※ 減速比 (■) 表輕負載機型。 For light loading type.

- 在正常使用狀態下，產品保固期限一年。
- 本公司有權針對以上數據規格進行設計變更不另行通知。
- Under normal usage, products come with a one-year limited warranty.
- Specifications subject to change without notice.



G12T

立式刀臂用齒輪馬達

V-CASING TYPE PRECISION GEAR MOTOR FOR ATC

立式標準型馬達的接線盒位置在270°
 Terminal box position: At 270° for foot - mount type.



G12V560S-MH10T用於刀庫圖示
 G12V560S-MH10T on ATC.

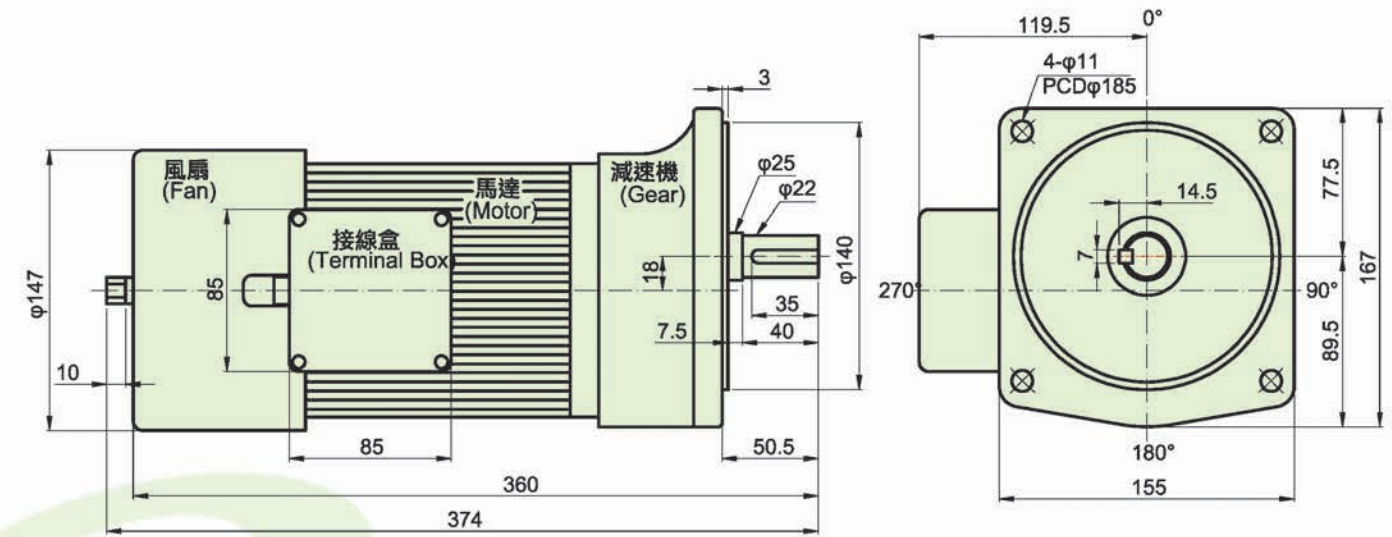

◎ 刀臂用齒輪馬達特性 FEATURES										
機種名 MODEL	功率 OUTPUT (W)	電壓 VOLTAGE (V)	電流 CURRENT (A)	轉速 SPEED (RPM)	減速比 GEAR RATIO	輸出轉矩 OUTPUT TORQUE (N-m)	輸出轉速 OUTPUT SPEED (RPM)	煞車電壓 BRAKE VOLTAGE (V)	停止時間 STOP TIME (ms)	過轉角度 OVER RUN DEGREE
G12V400S- MH10T	400	3 相220(50Hz)	2.84	1350	10	28.9	135	90~99	<90ms	<70°
		3 相380(50Hz)	1.58	1350		28.7	135			
		3 相220(60Hz)	2.89	1600		24.6	160		<75ms	
		3 相380(60Hz)	1.64	1600		24.1	165			
G12V560S- MH10T	560	3 相220(50Hz)	3.54	1300	10	41.8	130	90~99	<90ms	<70°
		3 相380(50Hz)	2.04	1300		41.7	130			
		3 相220(60Hz)	3.43	1550		34.5	155		<80ms	
		3 相380(60Hz)	1.95	1550		35.1	155			

Note:

1.停止時間:減速馬達空載狀態下,煞車器電壓釋放後至減速馬達完全停止,完全停止所需的時間依負荷大小會有長短。

Note: 1. Stop Time: As voltage brake release its voltage, the motor will gradually slow down to complete stop. The time frame required the motor to completely stop will depend on motor's loading.

2.過轉角度:減速馬達空載狀態下,煞車器電壓釋放後至減速馬達完全停止,其間輸出軸所運轉的角度依負荷大小會有長短。

2. Over run degree: As voltage brake release its voltage, the motor will gradually slow down to complete stop. The operation of the output shaft angle might be off from its original setting, as it is depend on motor's loading.



G11H-100W

臥式單相、三相齒輪馬達 SINGLE/3-PHASE FOOT-MOUNT TYPE PRECISION GEAR MOTOR

臥式標準型馬達的接線盒位置在270°
Terminal box position: At 270° for foot - mount type.

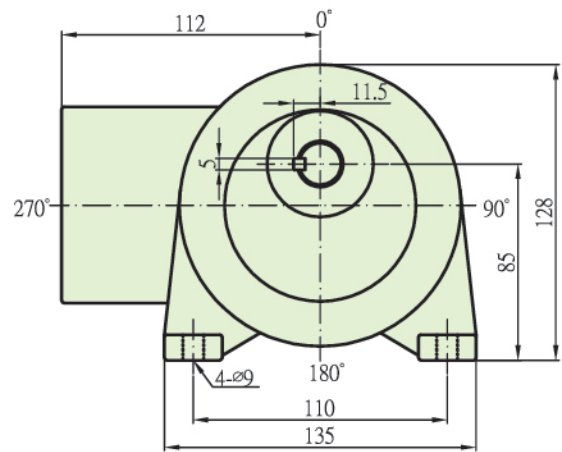
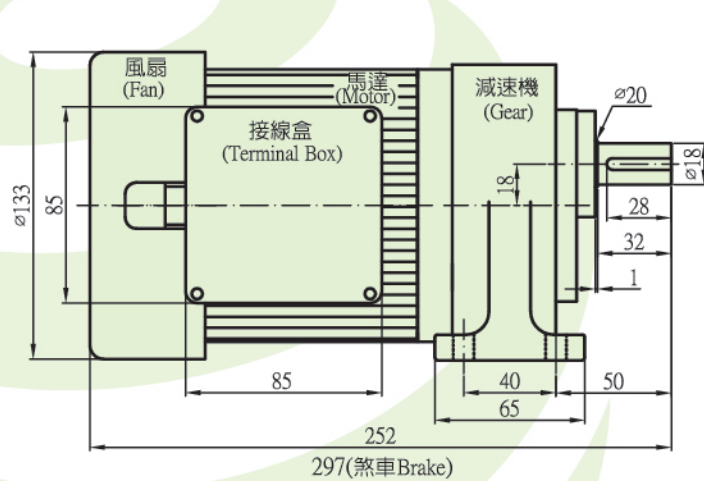

馬力 (KW)	全負荷電流 Full Load Current (amp)								全負荷迴轉數 Full Load Running (rpm)	
	三相 (3 Phase)				單相 (1 Phase)					
	220V		380V		100V	110V	200V	220V	50HZ	60HZ
	50HZ	60HZ	50HZ	60HZ	50HZ	60HZ	50HZ	60HZ		
100W	0.66	0.58	0.35	0.32	2.42	1.89	1.11	1.06	1400	1700

◎ 齒輪減速馬達性能表 GEAR MOTOR SPECIFICATION

減速比 Gear Ratio	3		5		10		15		20		25		30		40		50		60		75		90	
	50HZ	60HZ	50HZ	60HZ	50HZ	60HZ	50HZ	60HZ	50HZ	60HZ	50HZ	60HZ	50HZ	60HZ	50HZ	60HZ	50HZ	60HZ	50HZ	60HZ	50HZ	60HZ	50HZ	60HZ
出力同步回轉速 Output rpm	500	600	300	360	150	180	100	120	75	90	60	72	50	60	37.5	45	30	36	25	30	20	24	16	20
馬達額定輸出轉矩 Output Torque 單位: kg.m	0.18	0.15	0.3	0.26	0.6	0.51	0.89	0.76	1.2	1.02	1.31	1.12	1.58	1.35	2.02	1.8	2.62	2.25	3.15	2.7	3.94	3.6	4.73	4.59

- 立式 100W
- 立式 200W
- 立式 400W
- 立式 750W
- 立式 1500W
- 立式 2200W
- 臥式 100W
- 臥式 200W
- 臥式 400W
- 臥式 750W
- 臥式 1500W
- 臥式 2200W



G12H-100W

臥式單相、三相齒輪馬達
 SINGLE/3-PHASE FOOT-MOUNT
 TYPE PRECISION GEAR MOTOR

臥式標準型馬達的接線盒位置在270°
 Terminal box position: At 270° for foot - mount type.

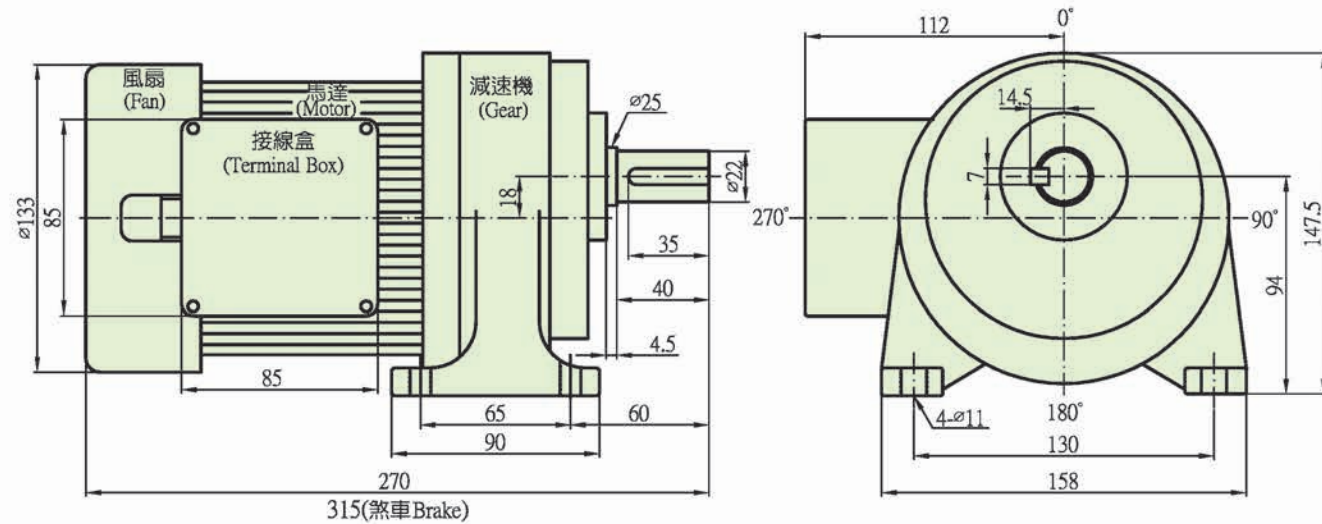

G11H-200W

臥式單相、三相齒輪馬達
 SINGLE/3-PHASE FOOT-MOUNT
 TYPE PRECISION GEAR MOTOR

臥式標準型馬達的接線盒位置在270°
 Terminal box position: At 270° for foot - mount type.

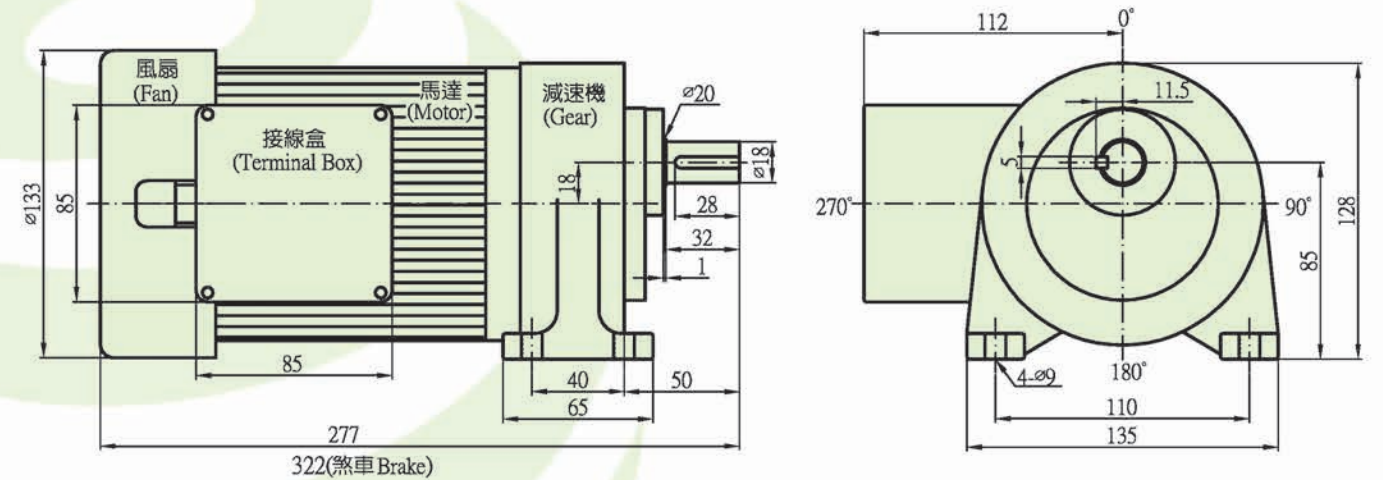

馬力 (KW)	全負荷電流 Full Load Current (amp)								全負荷迴轉數 Full Load Running (rpm)	
	三相 (3 Phase)				單相 (1 Phase)					
	220V		380V		100V	110V	200V	220V	50HZ	60HZ
	50HZ	60HZ	50HZ	60HZ	50HZ	60HZ	50HZ	60HZ		
100W	0.66	0.58	0.35	0.32	2.42	1.89	1.11	1.06	1400	1700

◎ 齒輪減速馬達性能表 GEAR MOTOR SPECIFICATION												
減速比 Gear Ratio	75		90		100		120		150		165	
	50HZ	60HZ	50HZ	60HZ	50HZ	60HZ	50HZ	60HZ	50HZ	60HZ	50HZ	60HZ
出力同步回轉速 Output rpm	20	24	16	20	15	18	12.5	15	10	12	9	11
馬達額定輸出轉矩 Output Torque 單位: kg.m	3.94	3.6	4.73	4.59	5.25	5.10	6.30	6.12	7.88	7.65	9.96	8.30

馬力 (KW)	全負荷電流 Full Load Current (amp)								全負荷迴轉數 Full Load Running (rpm)	
	三相 (3 Phase)				單相 (1 Phase)					
	220V		380V		100V	110V	200V	220V	50HZ	60HZ
	50HZ	60HZ	50HZ	60HZ	50HZ	60HZ	50HZ	60HZ		
200W	1.28	1.29	0.72	0.66	4.65	3.5	2.3	1.93	1400	1700

◎ 齒輪減速馬達性能表 GEAR MOTOR SPECIFICATION																										
減速比 Gear Ratio	3		5		7.5		10		15		20		25		30		40		50		60		75		90	
	50HZ	60HZ	50HZ	60HZ	50HZ	60HZ	50HZ	60HZ	50HZ	60HZ	50HZ	60HZ	50HZ	60HZ	50HZ	60HZ	50HZ	60HZ	50HZ	60HZ	50HZ	60HZ	50HZ	60HZ	50HZ	60HZ
出力同步回轉速 Output rpm	500	600	300	360	200	240	150	180	100	120	75	90	60	72	50	60	37.5	45	30	36	25	30	20	24	16	20
馬達額定輸出轉矩 Output Torque 單位: kg.m	0.36	0.31	0.6	0.52	0.9	0.75	1.19	1.02	1.79	1.53	2.1	1.8	2.63	2.25	3.15	2.7	4.2	3.6	5.25	4.5	6.3	5.4	7.88	6.75	9.45	8.1

- 立式 100W
- 立式 200W
- 立式 400W
- 立式 750W
- 立式 1500W
- 立式 2200W
- 臥式 100W
- 臥式 200W
- 臥式 400W
- 臥式 750W
- 臥式 1500W
- 臥式 2200W



G12H-200W

臥式單相、三相齒輪馬達
 SINGLE/3-PHASE FOOT-MOUNT
 TYPE PRECISION GEAR MOTOR

臥式標準型馬達的接線盒位置在270°
 Terminal box position: At 270° for foot - mount type.

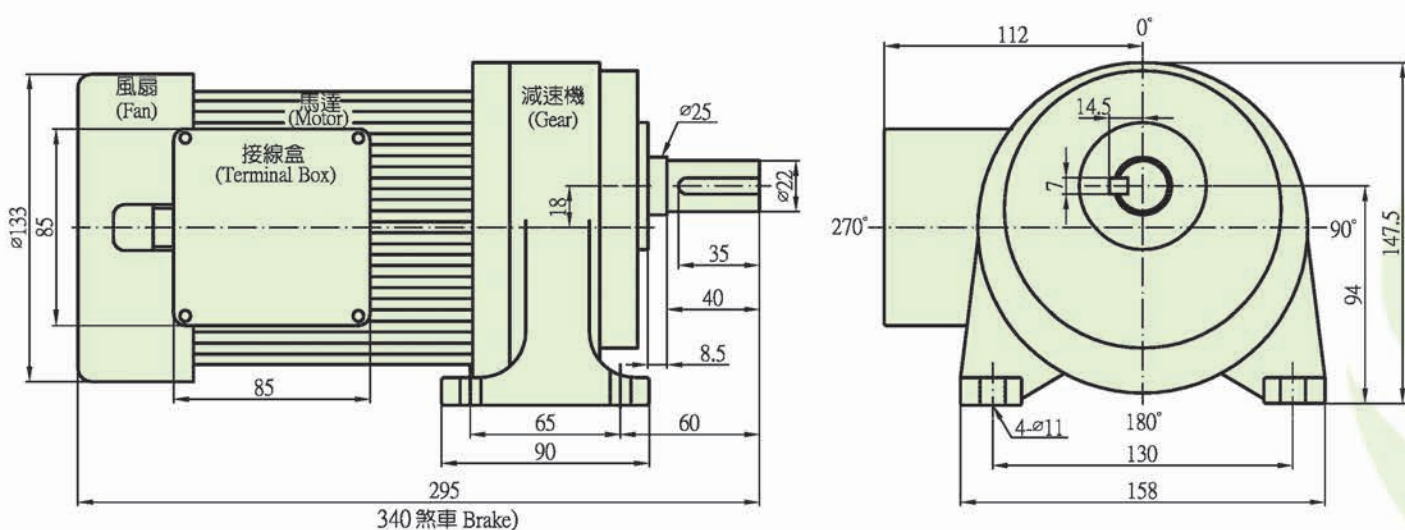

G13H-200W

臥式單相、三相齒輪馬達
 SINGLE/3-PHASE FOOT-MOUNT
 TYPE PRECISION GEAR MOTOR

臥式標準型馬達的接線盒位置在270°
 Terminal box position: At 270° for foot - mount type.

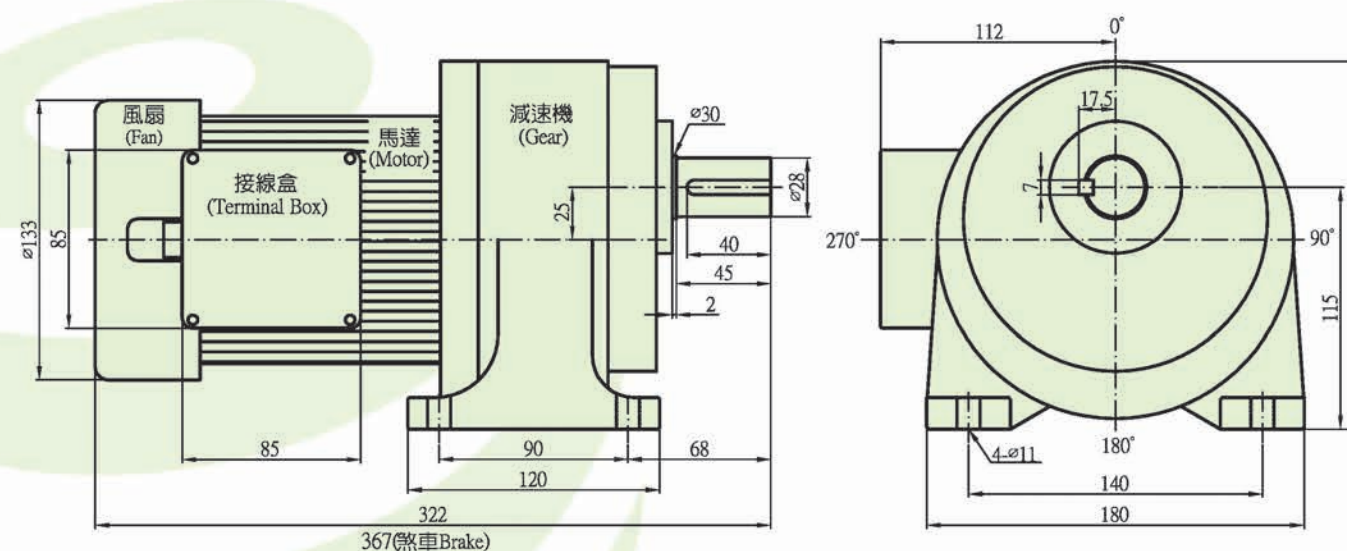

馬力 (KW)	全負荷電流 Full Load Current (amp)								全負荷迴轉數 Full Load Running (rpm)	
	三相 (3 Phase)				單相 (1 Phase)					
	220V		380V		100V	110V	200V	220V	50HZ	60HZ
	50HZ	60HZ	50HZ	60HZ	50HZ	60HZ	50HZ	60HZ		
200W	1.28	1.29	0.72	0.66	4.65	3.5	2.3	1.93	1400	1700

馬力 (KW)	全負荷電流 Full Load Current (amp)								全負荷迴轉數 Full Load Running (rpm)	
	三相 (3 Phase)				單相 (1 Phase)					
	220V		380V		100V	110V	200V	220V	50HZ	60HZ
	50HZ	60HZ	50HZ	60HZ	50HZ	60HZ	50HZ	60HZ		
200W	1.28	1.29	0.72	0.66	4.65	3.5	2.3	1.93	1400	1700

齒輪減速馬達性能表 GEAR MOTOR SPECIFICATION																								
減速比 Gear Ratio	20		30		40		50		60		75		80		90		100		120		150		165	
	50HZ	60HZ	50HZ	60HZ	50HZ	60HZ	50HZ	60HZ	50HZ	60HZ	50HZ	60HZ	50HZ	60HZ	50HZ	60HZ	50HZ	60HZ	50HZ	60HZ	50HZ	60HZ	50HZ	60HZ
出力同步回轉速 Output rpm	75	90	50	60	37.5	45	30	36	25	30	20	24	19	22.5	16	20	15	18	12.5	15	10	12	9	11
馬達額定輸出轉矩 Output Torque 單位: kg.m	2.10	1.80	3.15	2.70	4.20	3.60	5.25	4.50	6.30	5.40	7.88	6.75	9.65	8.04	9.45	8.10	10.59	9	12.6	10.8	15.75	13.5	19.92	16.6

齒輪減速馬達性能表 GEAR MOTOR SPECIFICATION										
減速比 Gear Ratio	100		120		150		165		180	
	50HZ	60HZ	50HZ	60HZ	50HZ	60HZ	50HZ	60HZ	50HZ	60HZ
出力同步回轉速 Output rpm	15	18	12.5	15	10	12	9	11	8	10
馬達額定輸出轉矩 Output Torque 單位: kg.m	10.59	9	12.6	10.8	15.75	13.5	19.92	16.6	21.73	18.11

立式 100W
 立式 200W
 立式 400W
 立式 750W
 立式 1500W
 立式 2200W
 臥式 100W
 臥式 200W
 臥式 400W
 臥式 750W
 臥式 1500W
 臥式 2200W



G12H -400W

臥式單相、三相齒輪馬達 SINGLE/3-PHASE FOOT-MOUNT TYPE PRECISION GEAR MOTOR

臥式標準型馬達的接線盒位置在270°
Terminal box position: At 270° for foot - mount type.

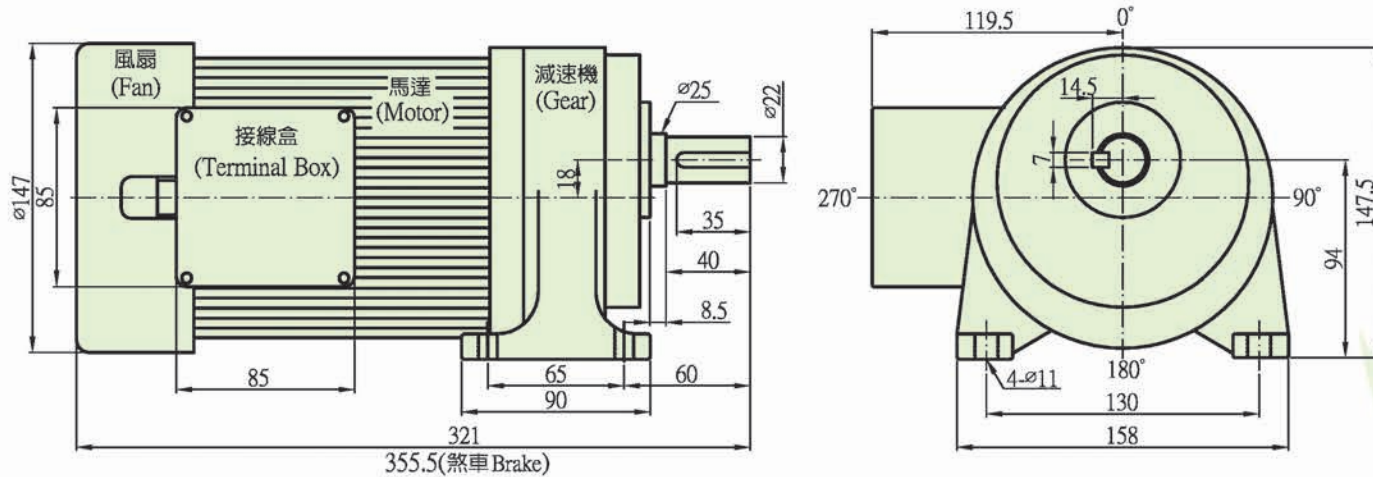

G13H -400W

臥式單相、三相齒輪馬達 SINGLE/3-PHASE FOOT-MOUNT TYPE PRECISION GEAR MOTOR

臥式標準型馬達的接線盒位置在270°
Terminal box position: At 270° for foot - mount type.

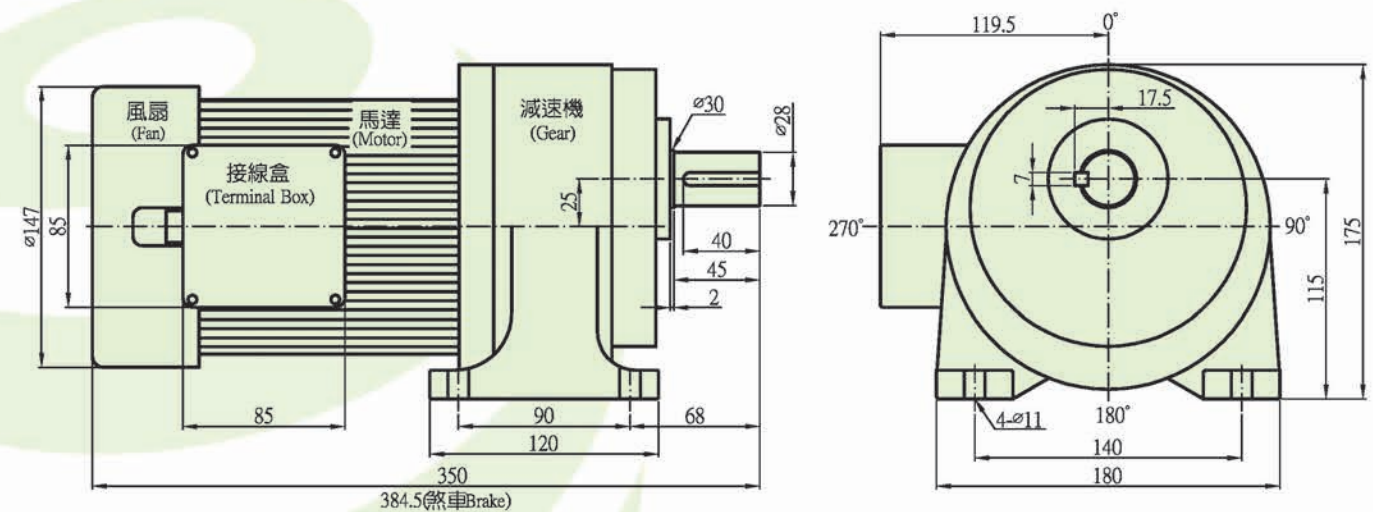

馬力 (KW)	全負荷電流 Full Load Current (amp)								全負荷迴轉數 Full Load Running (rpm)	
	三相 (3 Phase)				單相 (1 Phase)					
	220V		380V		100V	110V	200V	220V	50HZ	60HZ
	50HZ	60HZ	50HZ	60HZ	50HZ	60HZ	50HZ	60HZ		
400W	2.28	1.87	1.32	1.09	8.28	7.48	4.26	4.54	1400	1700

齒輪減速馬達性能表 GEAR MOTOR SPECIFICATION

減速比 Gear Ratio	3	5	7.5	10	15	20	25	30	40	50	60	75	90													
輸出同步回轉速 Output rpm	500	600	300	360	200	240	150	180	100	120	75	90	60	72	50	60	37.5	45	30	36	25	30	20	24	16	20
馬達額定輸出轉矩 Output Torque 單位: kg.m	0.74	0.62	1.24	1.04	1.86	1.55	2.48	2.07	3.71	3.11	4.40	3.68	5.50	4.60	6.60	5.52	8.80	7.36	11.00	9.20	13.20	11.04	16.50	13.80	19.80	16.56

馬力 (KW)	全負荷電流 Full Load Current (amp)								全負荷迴轉數 Full Load Running (rpm)	
	三相 (3 Phase)				單相 (1 Phase)					
	220V		380V		100V	110V	200V	220V	50HZ	60HZ
	50HZ	60HZ	50HZ	60HZ	50HZ	60HZ	50HZ	60HZ		
400W	2.28	1.87	1.32	1.09	8.28	7.48	4.26	4.54	1400	1700

齒輪減速馬達性能表 GEAR MOTOR SPECIFICATION

減速比 Gear Ratio	50	60	75	90	100	120	150	165	180									
輸出同步回轉速 Output rpm	30	36	25	30	20	24	16	20	15	18	12.5	15	10	12	9	11	8	10
馬達額定輸出轉矩 Output Torque 單位: kg.m	11.00	9.20	13.20	11.04	16.50	13.80	19.80	16.56	22.00	18.40	26.40	22.08	33.00	27.60	36.30	30.36	39.60	33.12

- 立式 100W
- 立式 200W
- 立式 400W
- 立式 750W
- 立式 1500W
- 立式 2200W
- 臥式 100W
- 臥式 200W
- 臥式 400W
- 臥式 750W
- 臥式 1500W
- 臥式 2200W



G14H -400W

臥式單相、三相齒輪馬達 SINGLE/3-PHASE FOOT-MOUNT TYPE PRECISION GEAR MOTOR

臥式標準型馬達的接線盒位置在270°
Terminal box position: At 270° for foot - mount type.

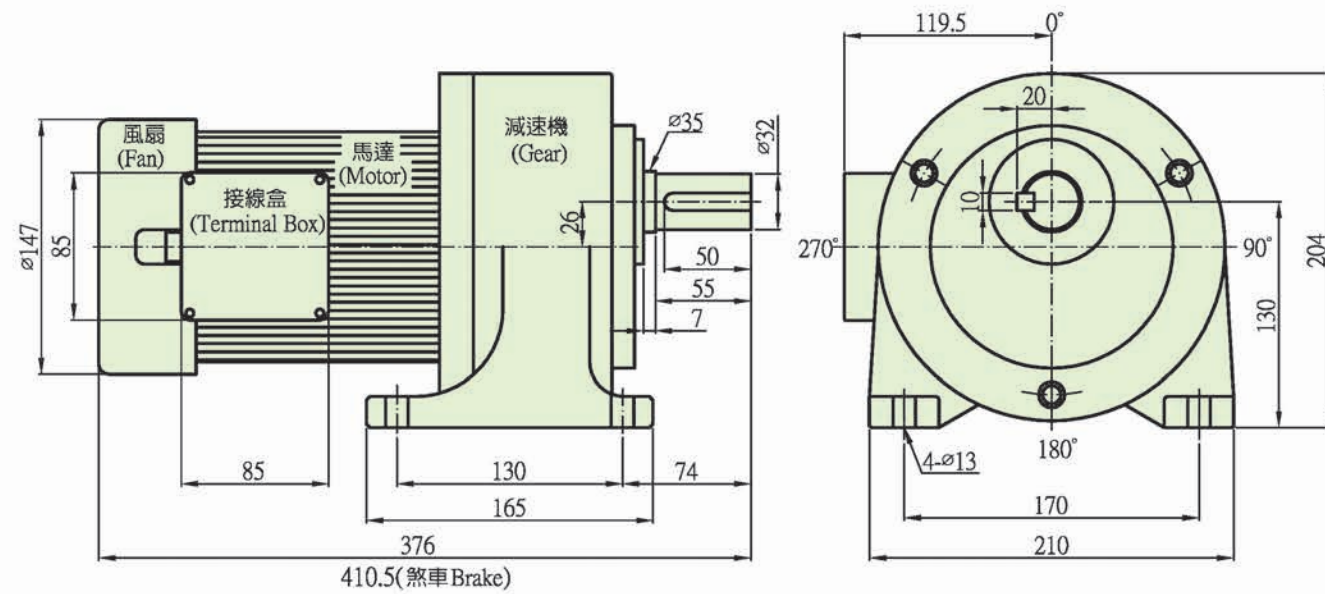

G13H -750W

臥式單相、三相齒輪馬達 SINGLE/3-PHASE FOOT-MOUNT TYPE PRECISION GEAR MOTOR

臥式標準型馬達的接線盒位置在270°
Terminal box position: At 270° for foot - mount type.

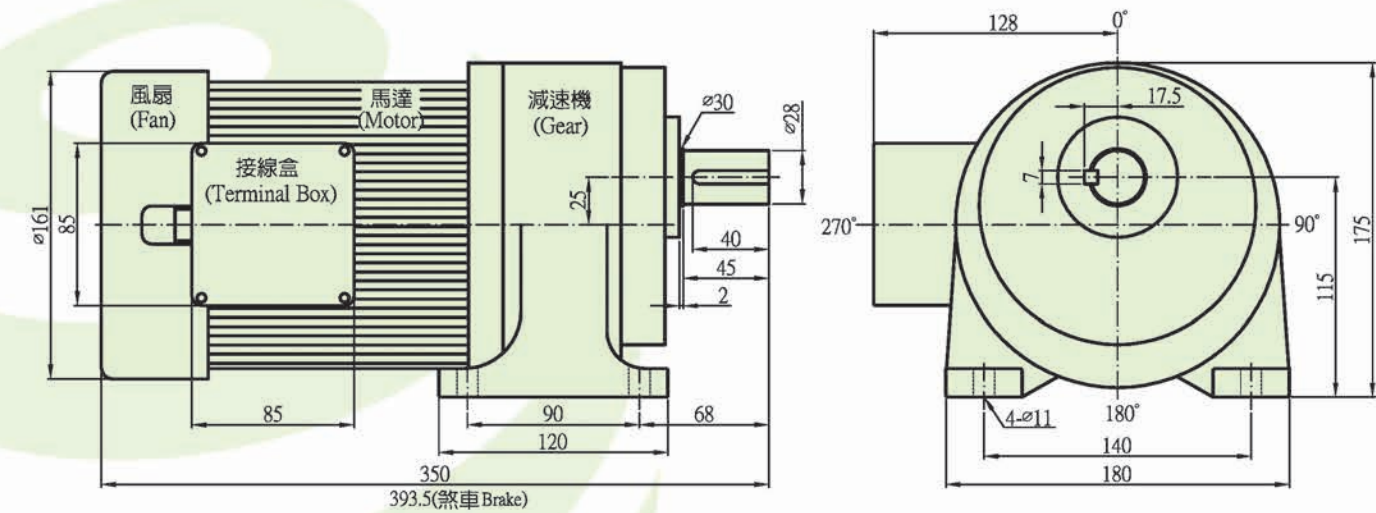

馬力 (KW)	全負荷電流 Full Load Current (amp)								全負荷迴轉數 Full Load Running (rpm)	
	三相 (3 Phase)				單相 (1 Phase)					
	220V		380V		100V	110V	200V	220V	50HZ	60HZ
	50HZ	60HZ	50HZ	60HZ	50HZ	60HZ	50HZ	60HZ		
400W	2.28	1.87	1.32	1.09	8.28	7.48	4.26	4.54	1400	1700

◎ 齒輪減速馬達性能表 GEAR MOTOR SPECIFICATION											
減速比 Gear Ratio	100		120		150		165		180		
	50HZ	60HZ	50HZ	60HZ	50HZ	60HZ	50HZ	60HZ	50HZ	60HZ	
出力同步回轉速 Output rpm	15	18	12.5	15	10	12	9	11	8	10	
馬達額定輸出轉矩 Output Torque 單位: kg.m	22.00	18.40	26.40	22.08	33.00	27.60	36.30	30.36	39.60	33.12	

馬力 (KW)	全負荷電流 Full Load Current (amp)								全負荷迴轉數 Full Load Running (rpm)	
	三相 (3 Phase)				單相 (1 Phase)					
	220V		380V		100V	110V	200V	220V	50HZ	60HZ
	50HZ	60HZ	50HZ	60HZ	50HZ	60HZ	50HZ	60HZ		
750W	4.00	3.40	2.30	2.00	18.40	19.10	9.72	7.65	1400	1700

◎ 齒輪減速馬達性能表 GEAR MOTOR SPECIFICATION																								
減速比 Gear Ratio	3		5		10		15		20		25		30		40		50		60		75		90	
	50HZ	60HZ	50HZ	60HZ	50HZ	60HZ	50HZ	60HZ	50HZ	60HZ	50HZ	60HZ	50HZ	60HZ	50HZ	60HZ	50HZ	60HZ	50HZ	60HZ	50HZ	60HZ	50HZ	60HZ
出力同步回轉速 Output rpm	500	600	300	360	150	180	100	120	75	90	60	72	50	60	37.5	45	30	36	25	30	20	24	16	20
馬達額定輸出轉矩 Output Torque 單位: kg.m	1.40	1.19	2.34	1.98	4.68	3.96	7.02	5.94	8.32	7.04	10.48	8.80	12.48	10.56	16.64	14.08	20.80	17.60	24.96	21.12	31.20	26.40	37.44	31.68

- 立式 100W
- 立式 200W
- 立式 400W
- 立式 750W
- 立式 1500W
- 立式 2200W
- 臥式 100W
- 臥式 200W
- 臥式 400W
- 臥式 750W
- 臥式 1500W
- 臥式 2200W



G14H -1500W

臥式單相、三相齒輪馬達
 SINGLE/3-PHASE FOOT-MOUNT
 TYPE PRECISION GEAR MOTOR

臥式標準型馬達的接線盒位置在270°
 Terminal box position: At 270° for foot - mount type.

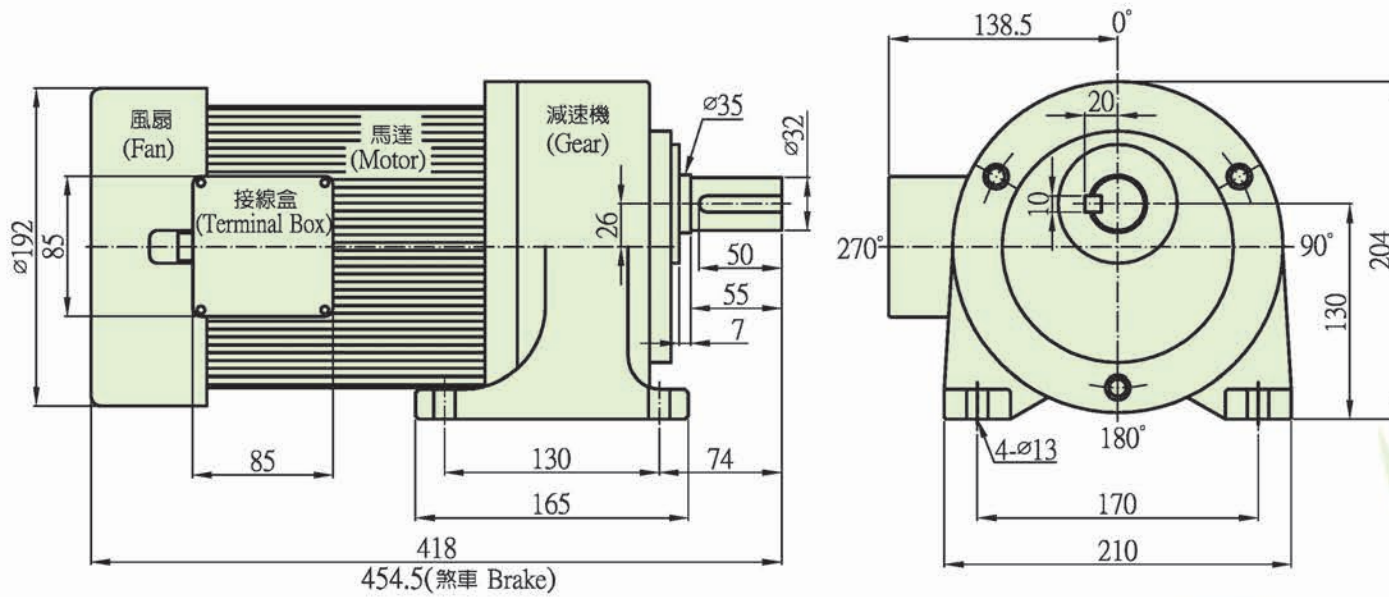

G15H -1500W

臥式單相、三相齒輪馬達
 SINGLE/3-PHASE FOOT-MOUNT
 TYPE PRECISION GEAR MOTOR

臥式標準型馬達的接線盒位置在270°
 Terminal box position: At 270° for foot - mount type.

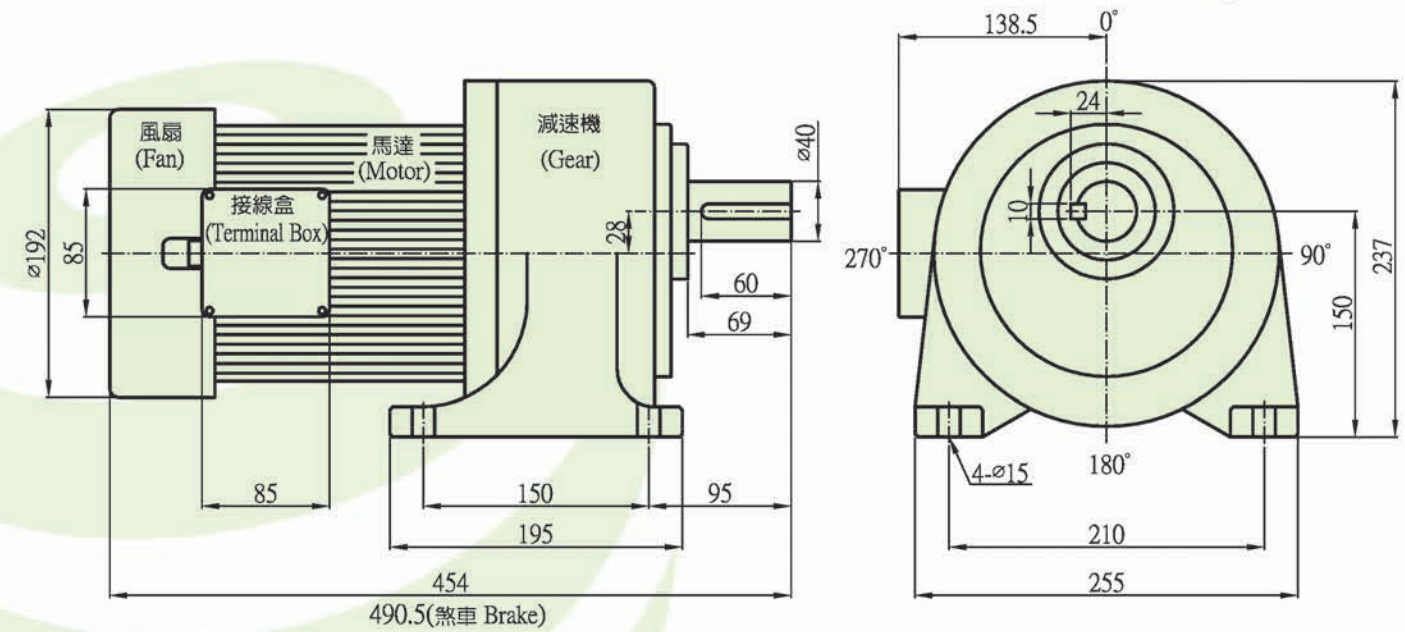

馬力 (KW)	全負荷電流 Full Load Current (amp)				全負荷迴轉數 Full Load Running (rpm)	
	三相 (3 Phase)					
	220V		380V			
	50HZ	60HZ	50HZ	60HZ	50HZ	60HZ
1500W	7.44	6.66	4.09	3.75	1400	1700

馬力 (KW)	全負荷電流 Full Load Current (amp)				全負荷迴轉數 Full Load Running (rpm)	
	三相 (3 Phase)					
	220V		380V			
	50HZ	60HZ	50HZ	60HZ	50HZ	60HZ
1500W	7.44	6.66	4.09	3.75	1400	1700

◎ 齒輪減速馬達性能表 GEAR MOTOR SPECIFICATION

減速比 Gear Ratio	3		5		10		15		20		25		30		40		50		60	
	50HZ	60HZ	50HZ	60HZ	50HZ	60HZ	50HZ	60HZ	50HZ	60HZ	50HZ	60HZ	50HZ	60HZ	50HZ	60HZ	50HZ	60HZ	50HZ	60HZ
出力同步回轉速 Output rpm	500	600	300	360	150	180	100	120	75	90	60	72	50	60	37.5	45	30	36	25	30
馬達額定輸出轉矩 Output Torque 單位: kg.m	2.75	2.27	4.59	3.78	9.18	7.57	13.77	11.35	18.36	15.13	20.25	16.69	24.3	20.03	32.4	26.7	40.5	33.38	48.6	40.05

◎ 齒輪減速馬達性能表 GEAR MOTOR SPECIFICATION

減速比 Gear Ratio	50		60		75		80		90		100	
	50HZ	60HZ	50HZ	60HZ	50HZ	60HZ	50HZ	60HZ	50HZ	60HZ	50HZ	60HZ
出力同步回轉速 Output rpm	30	36	25	30	20	24	19	22.5	16	20	15	18
馬達額定輸出轉矩 Output Torque 單位: kg.m	40.5	33.38	48.6	40.05	60.75	50.06	72.44	60.37	72.9	60.08	90.58	75.46

立式 100W
 立式 200W
 立式 400W
 立式 750W
 立式 1500W
 立式 2200W
 臥式 100W
 臥式 200W
 臥式 400W
 臥式 750W
 臥式 1500W
 臥式 2200W



G14H - 2200W

臥式單相、三相齒輪馬達
 SINGLE/3-PHASE FOOT-MOUNT
 TYPE PRECISION GEAR MOTOR

臥式標準型馬達的接線盒位置在270°
 Terminal box position: At 270° for foot - mount type.

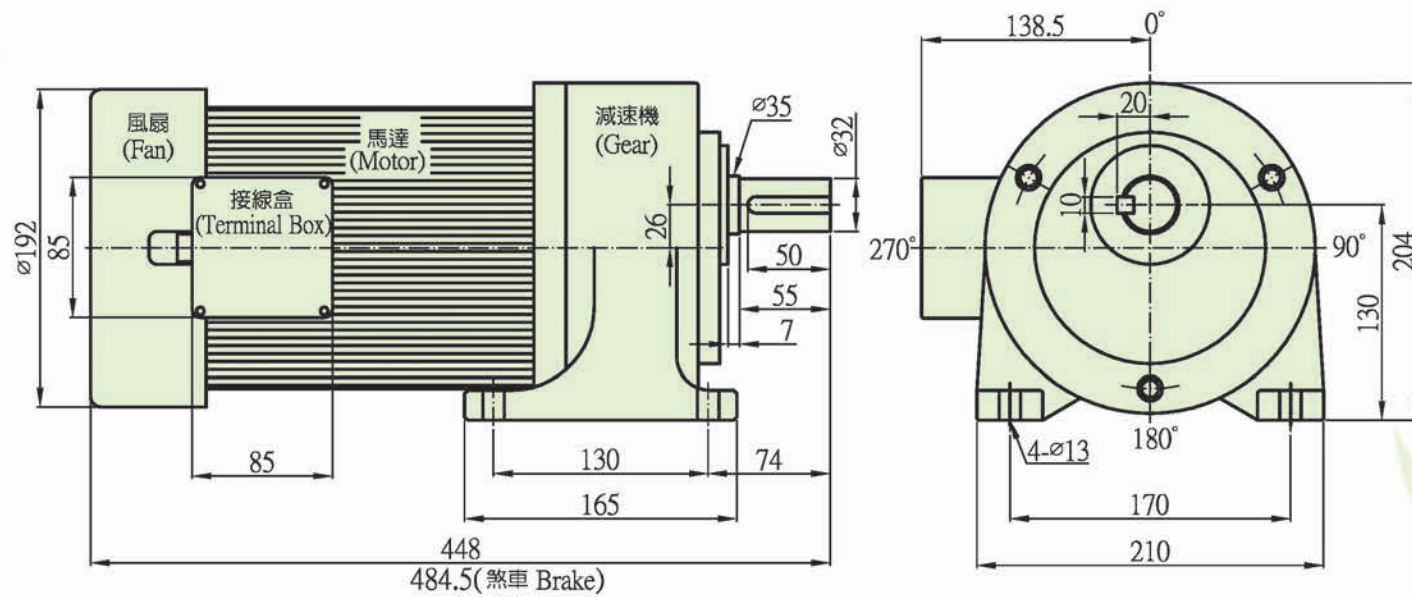

G15H - 2200W

臥式單相、三相齒輪馬達
 SINGLE/3-PHASE FOOT-MOUNT
 TYPE PRECISION GEAR MOTOR

臥式標準型馬達的接線盒位置在270°
 Terminal box position: At 270° for foot - mount type.

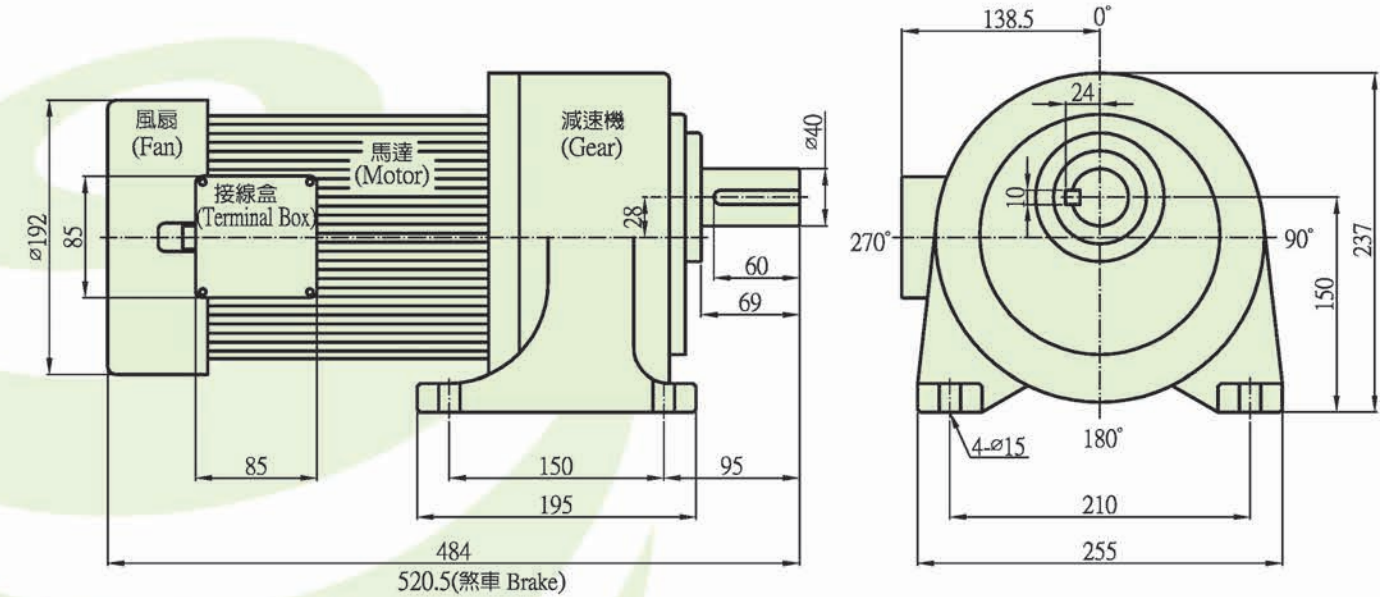

馬力 (KW)	全負荷電流 Full Load Current (amp)				全負荷迴轉數 Full Load Running (rpm)	
	三相 (3 Phase)					
	220V		380V			
	50HZ	60HZ	50HZ	60HZ	50HZ	60HZ
2200W	9.38	8.87	5.24	5.15	1400	1700

◎ 齒輪減速馬達性能表 GEAR MOTOR SPECIFICATION																
減速比 Gear Ratio	3		5		10		15		20		25		30		40	
	50HZ	60HZ	50HZ	60HZ	50HZ	60HZ	50HZ	60HZ	50HZ	60HZ	50HZ	60HZ	50HZ	60HZ	50HZ	60HZ
出力同步回轉速 Output rpm	500	600	300	360	150	180	100	120	75	90	60	72	50	60	37.5	45
馬達額定輸出轉矩 Output Torque 單位: kg.m	4.05	3.32	6.76	5.53	13.51	11.05	20.27	16.58	27.03	22.10	29.81	24.38	35.78	29.25	47.70	39.00

馬力 (KW)	全負荷電流 Full Load Current (amp)				全負荷迴轉數 Full Load Running (rpm)	
	三相 (3 Phase)					
	220V		380V			
	50HZ	60HZ	50HZ	60HZ	50HZ	60HZ
2200W	9.38	8.87	5.24	5.15	1400	1700

◎ 齒輪減速馬達性能表 GEAR MOTOR SPECIFICATION																												
減速比 Gear Ratio	3		5		10		15		20		25		30		40		50		60		75		80		90		100	
	50HZ	60HZ	50HZ	60HZ	50HZ	60HZ	50HZ	60HZ	50HZ	60HZ	50HZ	60HZ	50HZ	60HZ	50HZ	60HZ	50HZ	60HZ	50HZ	60HZ	50HZ	60HZ	50HZ	60HZ	50HZ	60HZ	50HZ	60HZ
出力同步回轉速 Output rpm	500	600	300	360	150	180	100	120	75	90	60	72	50	60	37.5	45	30	36	25	30	20	24	19	22.5	16	20	15	18
馬達額定輸出轉矩 Output Torque 單位: kg.m	4.05	3.32	6.76	5.53	13.51	11.05	20.27	16.58	27.03	22.1	29.81	24.38	35.78	29.25	47.7	39	50.24	41.62	79.68	66.4	99.61	83	106.25	88.54	119.53	99.61	132.81	110.67

立式 100W
 立式 200W
 立式 400W
 立式 750W
 立式 1500W
 立式 2200W
 臥式 100W
 臥式 200W
 臥式 400W
 臥式 750W
 臥式 1500W
 臥式 2200W